



**HOW MICHELIN IS PREPARING
FOR THE FUTURE OF MOBILITY**

Alexis Garcin

President and CEO, Michelin North America

MICHELIN NORTH AMERICA KEY FIGURES



EMPLOYEES

23,000



2 COUNTRIES

PRESENCE IN NORTH AMERICA

34 SITES



***MICHELIN-STARRED
RESTAURANTS***

242

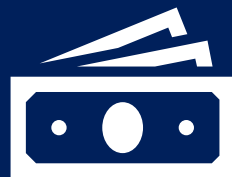

***MICHELIN NORTH AMERICA
2022 NET SALES***

\$9.1B

MICHELIN IS PROUD TO CALL SOUTH CAROLINA HOME



EMPLOYEES

8,000



PRESENCE IN SOUTH CAROLINA

14 SITES



DEDICATION TO THE STATE

50 YEARS

INVESTING IN THE UPSTATE THROUGH OUR ALL-SUSTAINABLE APPROACH

PEOPLE

***YOUTH APPRENTICE AND
TECH SCHOLAR PROGRAMS***



PROFIT

***GREENVILLE TRANSIT
AND ELECTRIC BUSES***



PLANET

UNITY PARK



A SUSTAINABLE MOBILITY COMPANY WITH MORE THAN 130 YEARS OF INNOVATION

1891

Detachable
tires

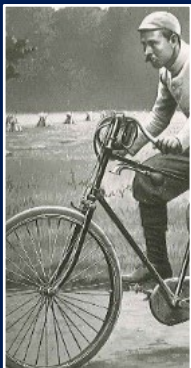

1916

1st paved
runway



1931

Road signs



1992

Energy Tire

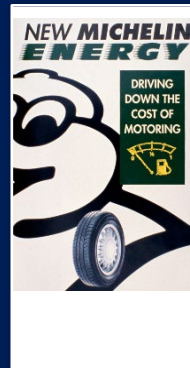

2019

Creation of
Symbio



1900

1st Michelin
Guide

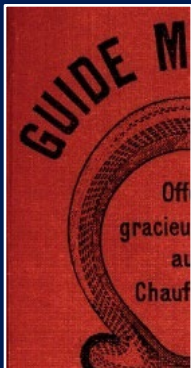

1929

Railcars



1946

Radial

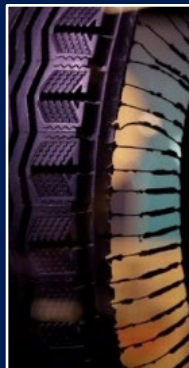

2017

Vision concept
Connected





LEADING INNOVATION



**WE CARE ABOUT GIVING EVERYONE A
BETTER WAY FORWARD**

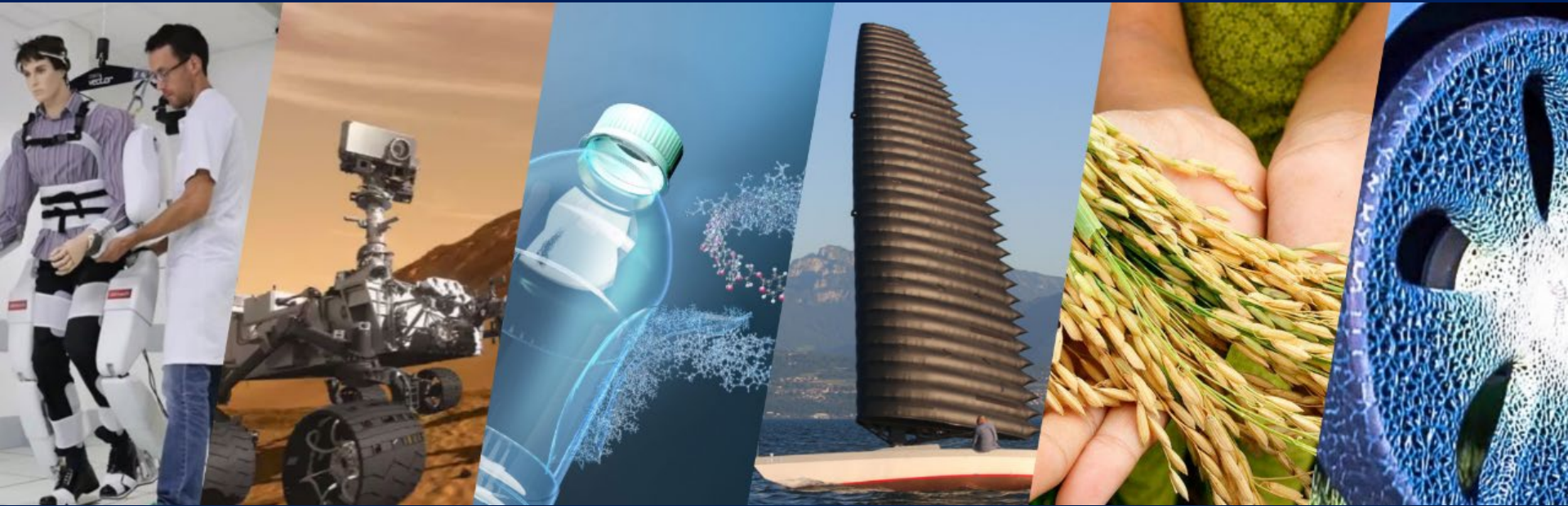

**BY 2050, MICHELIN IS RECOGNIZED AS A CRITICAL INNOVATION LEADER
THAT HELPED HUMANITY CONQUER NEW CHALLENGES.**



GLOBAL TRENDS AND GOALS



OUR "ALL SUSTAINABLE" APPROACH



PEOPLE

&



PLANET



PROFIT

ONE PORTFOLIO OF BRANDS SERVING ALL THE TIRE MARKETS AND BEYOND



A global brand



PURPOSE



GLOBAL TRENDS



STRATEGY



WITH TIRES, AROUND TIRES, BEYOND TIRES



ALL POWERED BY AND FOR PEOPLE



Three Areas of Evolution:



ELECTRIFICATION



GREEN TRUCKING



SMALLER ENVIRONMENTAL FOOTPRINT

Three Areas of Evolution:



ELECTRIFICATION



GREEN TRUCKING



SMALLER ENVIRONMENTAL FOOTPRINT

THE ELECTRIFICATION EVOLUTION

ELECTRIFICATION IS THE **BIGGEST
REVOLUTION IN AUTOMOTIVE
INDUSTRY SINCE INCEPTION**



**83% OF U.S. DRIVERS ARE UNSURE
OF WHAT TIRE AN EV NEEDS**

ELECTRIC VEHICLES WILL
REPRESENT **50% OF MARKET BY 2030**

INNOVATING TO MEET THE CHALLENGES OF THE EVOLUTION



- 1 EXTENDS RANGE BY 37 MILES**
- 2 MAXIMIZED WEAR WITH VERY LOW TIRE ABRASION**
- 3 20% LESS NOISE WITH MICHELIN ACOUSTIC TECHNOLOGY**



MICHELIN PILOT® SPORT EV

*THE **LUCID AIR** ELECTRIC VEHICLE AT MICHELIN*



Three Areas of Evolution:



ELECTRIFICATION



GREEN TRUCKING



SMALLER ENVIRONMENTAL FOOTPRINT

HYDROGEN AS A SOLUTION TO DECARBONIZE TRUCKING

MICHELIN, SYMBIO,
FAURECIA SELECTED
BY CALIFORNIA
ENERGY COMMISSION
TO BUILD A
HYDROGEN-FUELED
CLASS-8 TRUCK

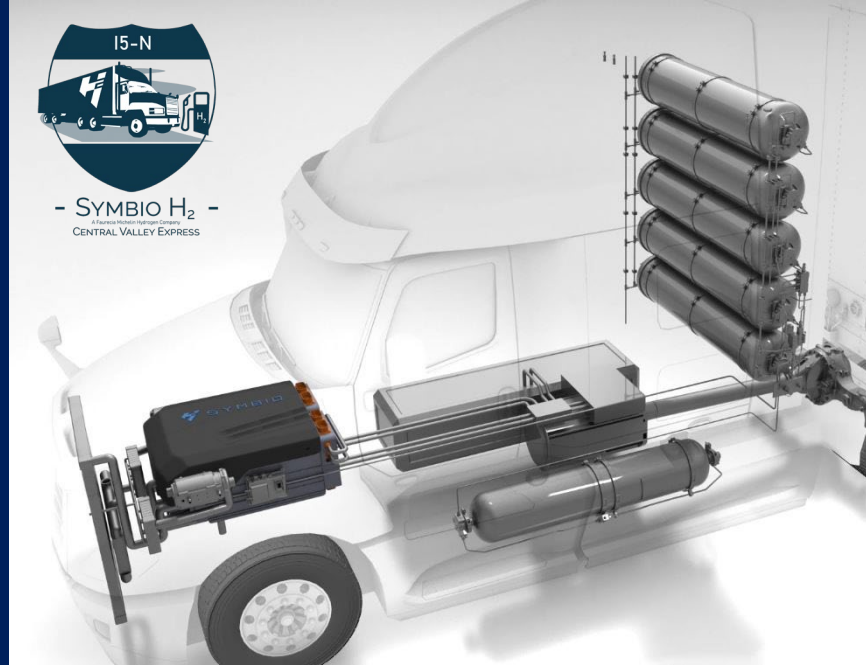

MICHELIN TO
PROVIDE LOW-
ROLLING
RESISTANCE
TIRES AND BRING
ITS 20 YEARS OF
HYDROGEN
EXPERIENCE

PARTNERING WITH LOCAL LEADERS



Three Areas of Evolution:



ELECTRIFICATION



GREEN TRUCKING



SMALLER ENVIRONMENTAL FOOTPRINT

COMMITMENT TO SUSTAINABLE PRODUCTS





MICHELIN CONTINUES TO MAKE PROGRESS TOWARD ITS GOAL TO HAVE 100% SUSTAINABLE TIRES BY 2050



OUR "ALL SUSTAINABLE" APPROACH



PEOPLE

&



PLANET



PROFIT

HOLDING US TOGETHER...

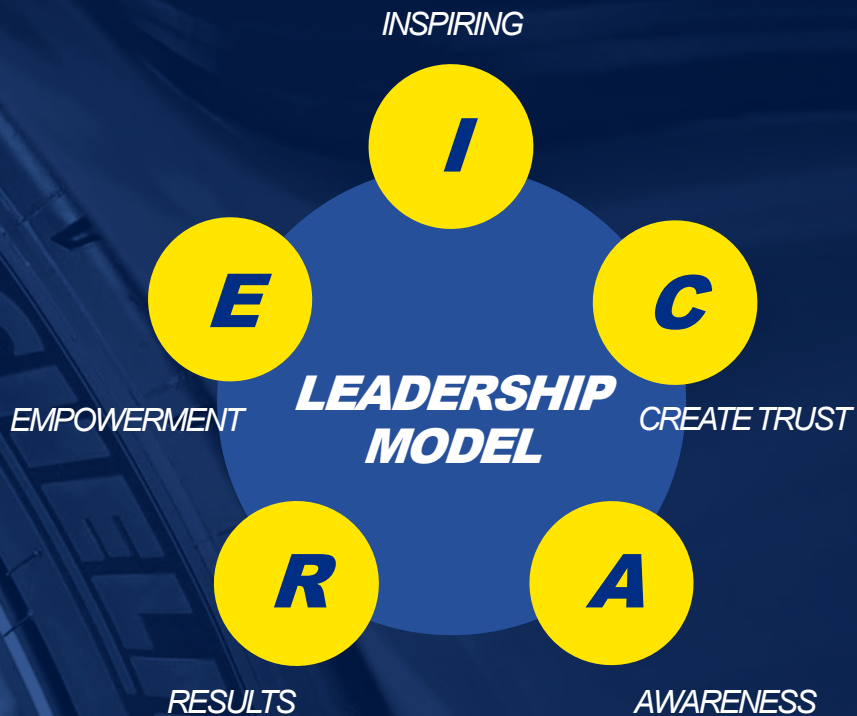
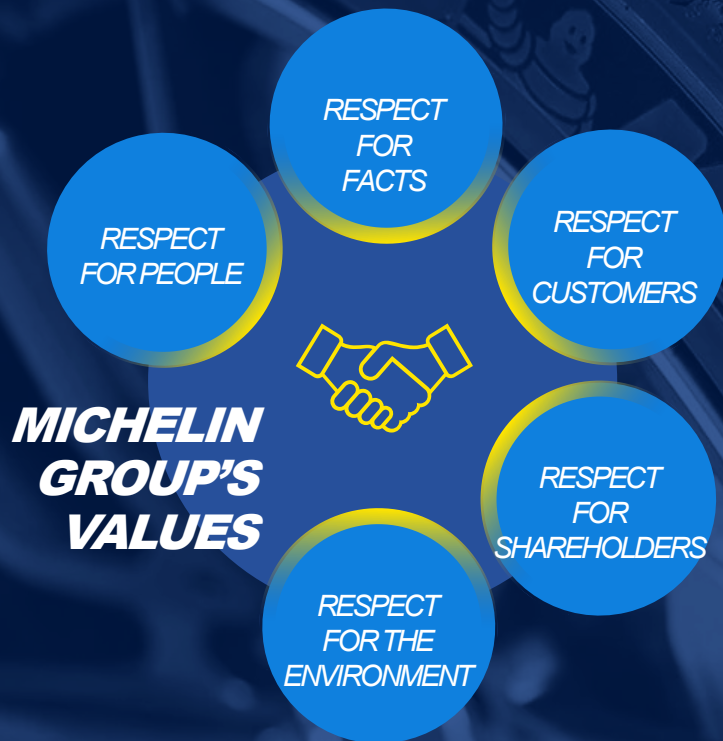



**PEOPLE MAKE
IT POSSIBLE**

**WE CARE ABOUT GIVING EVERYONE A
BETTER WAY FORWARD**

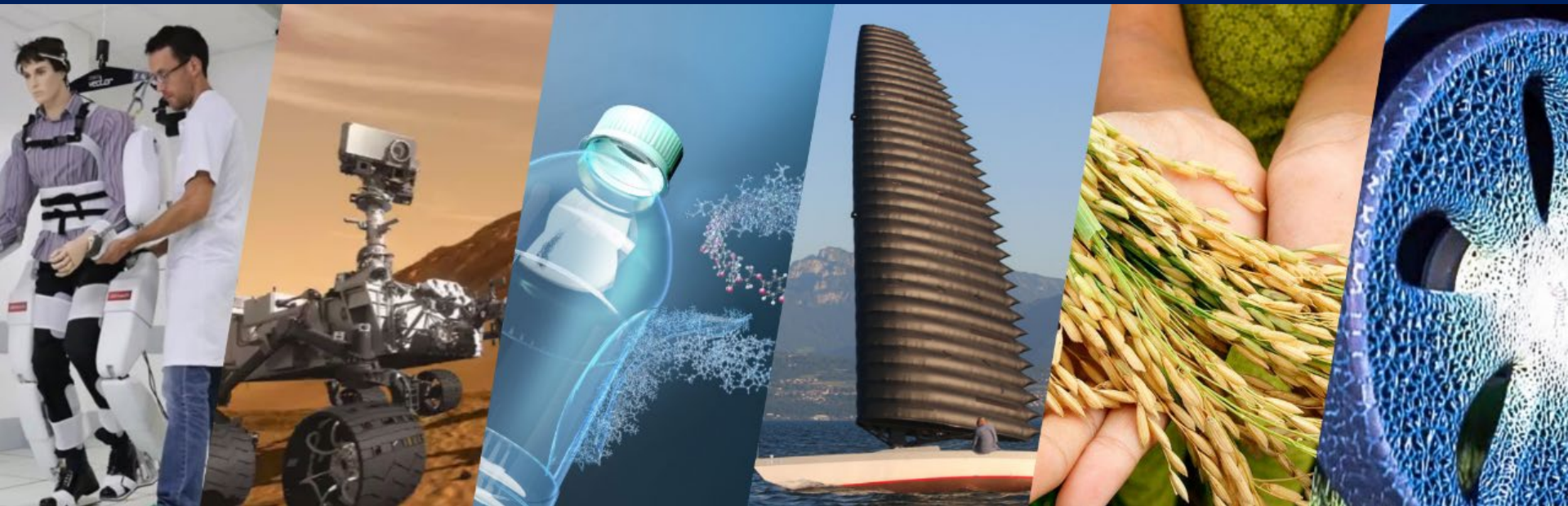

**BY 2050, MICHELIN IS RECOGNIZED AS A CRITICAL INNOVATION LEADER
THAT HELPED HUMANITY CONQUER NEW CHALLENGES.**